



Full - Year
 SUBSCRIPTION
 \$4.98

Published First Day Of Every Other Month

VOLUME 1 NO. 4

Publication Office: 210 West 28th Street, Baltimore, Maryland 21211

NOV. 64

"BEST FOOTBALL GAME EVER INVENTED"

"honest-to-Pete challenge to the man who knows he would have been a great pro Quarterback" says Sports Illustrated

As this magazine goes to press, the eyes and ears of the country are centered on football. Many college conferences are building up to their championship games while the pros are delighting in the best year ever. Our own Baltimore Colts, perennial powerhouse of the NFL, are once again slashing their way toward another championship skein. Small wonder; their offices are practically next door to the author of Football Strategy.

Sports Illustrated Magazine said... "Football Strategy is the best football game ever invented." Magazines of the literary quality of Sports Illustrated don't usually make unequivocal statements such as this... unless the product's top notch. Our design department thinks its a great game (perhaps some bias here) and they are still playing it on their lunch hours.

Lunch-time Leagues

As a matter of fact, lunch-time Football Strategy leagues have become the latest fad. For instance, from a leading New York advertising agency, came this testimonial...

"When you can get a dozen top-notch advertising men to pass up expense account lunches at their choice of New York's better restaurants, you

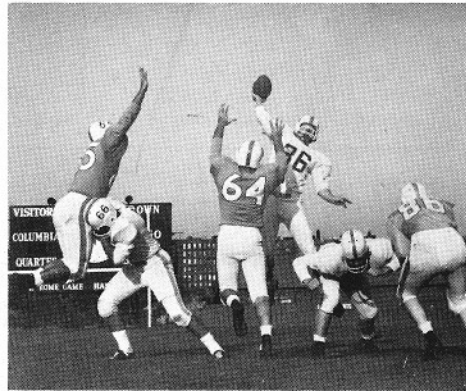

FOOTBALL STRATEGY isn't this realistic but those in the know claim its the next best thing to actually playing the game!

must have a real attraction going for you. That's what Football Strategy has been doing here at Benton & Bowles for the past ten or twelve weeks. We want to congratulate you on having devised this truly great game. Several of us who have played college football, and some who just love the game from a spectator point of view, have been at various times attracted by various football games that have been introduced in the last four or five years. Most of them depend on mathematical gimmicks, lights, dials, dice -- but none of

(Continued on page 2)

The Avalon Hill Phantom Strikes Again...

Who is the Avalon Hill Phantom?

We're not at liberty to say...he's still at large. And all of Baltimore is trying to figure out who is the person that's pasting up Avalon Hill "Decals" all over Baltimore town.

The "Don't Buy an Avalon Hill Game" Decals have been appearing in the most unusual places. In fact, the Phantom hasn't provoked so much laughter and good-hearted fun here in town since the days of the Cat Burglar.

Now we're going to let you in on the fun. If you are truly a devoted Avalon

Hill fan there's no reason in the world why you, too, can't help the Phantom spread the Avalon Hill gospel all around the country.

Spread the Gospel

All you'll need to become an Avalon Hill Phantom are the Decals and a pair of sun glasses. You'll need the sun glasses because the Decals are printed on a bright "Day-glo" orange background. "Day-glo" orange is the most striking

(Continued on Page 8)

Play-By-Mail League...

A wargamers play-by-mail league, operating out of Huntington, Indiana, has just been formed. For a very nominal fee, officers of the league will take care of the many-sided details of coordinating games and matching applicants up with opponents in play-by-mail games. In addition, they will undertake to rate players so that games between opponents can be played on as even a level as possible. Membership will be restricted to the first 250 applicants. The following information is

(Continued on Page 7)

Californians - Call to Arms

From the Tactics & Strategy Club of California comes the following blurb:

"What do AH games represent to you? Are they just games or do they represent a problem of life? Are you interested in joining a club with the emphasis on realism? Does military history, tactics, and strategy, interest you? If so we call upon you to join the TACTICS AND STRATEGY CLUB OF CALIFORNIA. Here you will meet players, who like yourself, find endless fascination in playing AH games as if from the general's HQ. Say that you don't live in California? That's simple just join our mail organization. If you are the first to write from your state perhaps you will be the one to organize a TACTICS AND STRATEGY club for your state. If you live near us please come in person." Write: George L. Phelps, T & S Club, 20624 Skouras Drive, Canoga Park, California 90136.

The History Book Club

We have been informed that The West Point Atlas of American Wars and A Military History and Atlas of Napoleonic Wars is available through the History Book Club, 40 Guernsey Street, Stamford, Connecticut. Thanks to Terrence P. Schweider for giving us this information.

★ ★ ★ ★ ★
The AVALON HILL **GENERAL**

a bi-monthly newsletter mailed on the 1st day of January, March, May, July, September and November.

EDITED & PUBLISHED by The Avalon Hill Company, Baltimore, Maryland.

Copyright 1964 T. A. H. C.
Baltimore, Maryland.
Printed in U. S. A.

"An honest-to-Pete challenge..."

(Continued from page 1)

them even approaches the realism or excitement of Strategy. Even non-footballers are attracted by the cerebral aspects of the game. Our Fierce Football League has just started its third season. All of its members are regular football fans so we prefer to wait until all that Intercollegiate and NFL nonsense is over before we throw ourselves into the greatest game ever invented. Our season will end when we have the championship Playoff between the Upstairs and Downstairs Divisions. The winner's name is engraved on a pewter mug which remains in his possession until the following season. Again, congratulations from the Fierce Football League who will be playing, and buying, the game for some time to come."

Avalon Hill is quite appreciative of the above, and many other fine testimonials about its games. Its tantamount to an actor being applauded, or a ball-player receiving a tumultuous ovation.

You are the Quarterback

To you who haven't been caught up in the recent football fever, let us say that the strategy inherent in this game could quite easily make you, too, a devoted Avalon Hill sports game fanatic.

We recognize that there are many realistic football games on the market designed on the order of our authentic battle titles. However, none puts you as squarely in the quarterback's slot as does Football Strategy, the game that dazzled the knowledgeable writers of Sports Illustrated.

Design Your Own Games

Amateur battle game inventors wishing to design their own can purchase plain white mapsheets containing hexagons on a white background. They are available on 22" x 28" sizes for \$1.00 per sheet. Quantity is limited at the present time.

"ALL Sports Digest"--for the Real Sports Fanatic

For those interested in sports table games along the complexity level of Avalon Hill battle games, we recommend you inquire about the "ALL Sports Digest." This is a splendid tabloid containing a diversity of articles and editorials on sports in general. Specifically, it includes a book review section; you are kept up to date on player trades; there are also human interest excerpts on players themselves...you might even learn which players have athletes feet. In addition, a study of their statistical section will show you things like how an obviously drugged Baltimore Colt team could lose to the ludicrous Minnesota Vikings. Write now to: ALL Sports Digest, 2309 E. 1st Street, Duluth, Minnesota 55812.

Chief of Staff's Reading List...

This list is indorsed by General Maxwell D. Taylor as basic professional reading recommended for Army officers.

Century Of Total War, by Raymond Aron, 1954.

Military Heritage Of America, by Cols. R. E. and T. N. Dupuy, 1956.

How Russia Is Ruled, by Merle Fainsod, 1953.

A Hundred Years Of War, by Capt. Cyril Falls, 1953.

Foreign Policy: The Next Phase, by Thomas K. Finletter, 1958.

Power And Policy, by Thomas K. Finletter, 1954.

Soviet Strategy In The Nuclear Age, by Raymond L. Garthoff, 1958.

Every Christmas...it's turkey...turkey...turkey!



this year be different...give
AVALON HILL GAMES

Naval Affairs

Walter Guerry Green III
P. O. Box 621
Burlington, N. Carolina



I have received a number of letters on my last column and wish to thank those who took time to write to me and offer their ideas on my subject matter. At the time when I wrote that article I did not have access to all my research materials and accordingly missed a number of heavy submarine types. In particular the boats of the U. S. Navy's Argonaut (1 vessel, 2710 tons, 2-6") and Nautilus (2 vessels, 2730 tons, 2-6") classes and the Royal Navy's X-1 (2425 tons, 4-5.2" in turret mounts with fire control) could have held their own in a gunnery duel. A number of Japanese types especially the I-1 (4 vessels, 1955 tons, 2-5.5") and I-7 (2 vessels, 1,950 tons, 2-5.5") classes would also have been tough opponents for the more lightly armed types of escorts. I have also been told that a number of Italian submarines mounted 4-3.9" although I have not been able to verify this yet.

Best References

In an attempt to make this column more useful I am going to steal Jon Perica's idea of a book list. To start off for World War II buffs I would suggest the following standard references:

Jane's Fighting Ships, editions 1938-46

Brassey's Annual, editions 1938-46
These two annuals are a must for those interested in the types of warships in use at this time and are extremely accurate. Jane's is really superior in that it contains photographs of all major classes wherever possible. Both of these serials are available at most good libraries.

More on U-Boat

To continue with my analysis of the game U-Boat I would like to offer some variations to the basic rules. As the present rules stand the basic game may easily be adapted to a World War I situation by the elimination of the all-seeing factor presently used. This goal may be accomplished by either using three separate boards and a referee or by use of two separate boards and a grouping of squares as in Bismarck. From a practical standpoint the use of a referee would probably be best as he could determine visibility and listening ranges. The maximum listening range for detection should perhaps be 1/4 or less of the board area, and any vessel

(Continued on Page 7)

New England

Thomas S. LaFarge
Groton School
Groton, Massachusetts



EDITOR - New England covering Maine, Vermont, New Hampshire, Massachusetts, Connecticut and Rhode Island.

Limited Intelligence Game

by Thomas La Farge

This is the description of a game of my design, based historically on the pre-Napoleonic wars of the eighteenth century, which involves the principle that opponents cannot see all of each other's dispositions.

This is not a game of any one battle or campaign, and various details are left to the players' imaginations, such as what locality is represented on the
(Continued on page 11)

The Element of Surprise

by Victor Madeja

Whoever is interested in doubling the realism of some A.H. war games need only follow all the following provisos.

A. Dummy Counters: These are to create the impression of troops where none exist. Any counter can serve the purpose. They have absolutely no combat value and can not be destroyed (treat as Rommel unit in A. K.); their movement rate varies. The number of "D" units an army has is determined generally by its number of troops. The speed of the unit is that of the troops it is representing (EX. below). Number of "D" counters per number of troops (all armies unless otherwise specified) in various games.

AFRIKA KORPS - 1 for 10 def. factors

WATERLOO - 1 to 25 factors

STALINGRAD - 1 for 25 def. factors

TACTICS - 1 for 6 offensive factors

D-DAY - 1 per 30 Allied factors

Germans receive four

Middle Atlantic

Victor Madeja
287 Bedford Avenue
Brooklyn, N. Y. 11211



EDITOR -- Middle Atlantic covering New York, New Jersey and Pennsylvania.

CHANCELLORSVILLE - 1 per 10 Conf. factors; 1 per 20 Unit fac.

EX. for finding movement of "D": in Stalingrad the Germans have 94 factors that move 6 and 171 that move 4. They would receive 3 "D" units that move 6 and 6 that move 4. (Exception: in A.K. there is an extra "D" that moves 6 or 12, German player's choice). If it is an arrival game, the "D" arrives with its quota troops.

B. Automatic Victory: As in A.K., is used in all above games. It requires mere common sense to justify this. Its specific purpose is to enable the immediate exploitation of surprise and prevent the occurrence of ridiculous situations (in Stalingrad it is possible for 2/2-3-6's to stop the advance of as many as 130 German factors for 1 month).

C. All counters are inverted, and remain so, until two opposing units enter within 2 sqs of each other. These particular units are immediately turned face-up and remain so until the distance between them increases.

Exceptions: In D-DAY only 15 units at a time can be inverted and only 2 of these during the invasion turns. However, the "D" units may be placed anywhere starting the first turn.

Gettysburg - A unit on a hilltop can "see" enemy units 2 miles away, on a crest 1 1/2 miles, on the plains 1 mile. The line of sight is a straight line and units can not see through a forest or hill square. To do so a unit must be two sqs away; this also applies if a unit is in a forest.

To tell movement of inverted units mark the green side with a number or symbol, also make a line from corner to corner on the red side.

To conceal units that have turned face up you need only form a temporary stack, secretly shuffle it, and continue moving.

That's it. Using this system it is possible to mass your troops secretly, to launch surprise attacks, launch feints, send out reconnaissance missions, and your skill will be given an even greater test than before.

Clarifications

In my last column about Waterloo I neglected to mention that the II and III

(Continued on Page 7)

Letters, Yes We Get Letters...

Dear Sirs,

Yesterday I received your September issue of the General. I know you must be very busy lobbying Congress to start WW III, but you should at least get your issues out on time so that we can enter the many "contests" which appear in it (i. e. Contest #3, or Operation Gigantis). G. Waldo Miller.

EDITOR'S NOTE: Because of the lateness of delivery, we will make every effort to rush out future copies to subscribers. We may even put first class stamps on the envelope.

Dear A. H.:

My September copy of the General didn't reach me until Sept. 28. No offense, but Guttenberg could have printed it faster and the Pony Express would have delivered it faster. You should send them out in such a way that everyone gets it about the same time, to make the contest fair. Bob Wood, 873 N. 10th Ave., Upland, Calif., 91786.

Gentlemen:

Please find enclosed a postal money order for five dollars and no cents (\$5.00). This money is for the purchase of one of your D-Day games.

By the way D-Day shows promise of becoming a new college game craze. John M. Sharp, 175 Frontier Hall, University of Minnesota, Minneapolis, 14, Minn.

Dear Sirs:

Your excellent games have moved me from the sand table to the dining room table.

There are several of us here in San Diego who devote a good ten hours a week to A-H tournament war-gaming (Monday and Friday nights). I've devised a system that is simple but interesting. It is as follows: We play Afrika Korps - Stalingrad - and D-Day in the order listed. Each individual takes the Germans for three games against the same opponent and then switches to take the Allies. It is scored in the following manner: The German player gets two points for winning Afrika Korps, two points for winning Stalingrad and one point for winning D-Day. If the German player wins all three games, he is awarded a ten point bonus. The Allied player gets one point for winning both Afrika Korps and Stalingrad with two points received for winning D-Day. If he wins all three, he gets an eight point bonus. We keep a total point standing for all members, and it has proven to be quite a competitive challenge... Bob Geasette.

Dear Sirs:

From the Sept. General Q: "If surrounded, can parachute units fly away and escape?" A: "Yes."

What are you guys running around there - an insane asylum? I didn't know

(Continued on Page 12)

South Atlantic

Hilary Smith
7805 Maple Ridge Rd.
Bethesda 14, Maryland



EDITOR - South Atlantic covering Maryland, D.C., West Virginia, Virginia, Kentucky, North Carolina, South Carolina, Georgia, Alabama, Mississippi and Florida.

In the absence of Mr. Smith's column for November is the following by Albert Nofi

The Long Romps!

by Albert Nofi

Sgt. Zocchi's truly masterful Operation Can Can (July issue) is a fine example of what a plan should be and an excellent offensive plan for Blue.

Since variety is the spice of life, and because I am running out of superlatives, I would like to offer my own favorite starting line-up which has afforded hours of successful conquests over startled foes. It is not necessary to follow the plan exactly and hence it takes considerably more than two games for your opponent to catch on.

The plan is based on the premise that Blue has the first turn and is useless otherwise. There are two parts to it, which I have labeled "Long Romp I" and "Long Romp II" for reasons which will readily be seen.

Long Romp I

This is an offensive operation against C 43-16.

Take 3d Arm Div at 28-33 and march 21 squares to square 42-16 of C 43-16.

March 1st and 2nd Amph Divs from 24-41 and 28-39 10 and 9 squares respectively to Blue Capital's two easternmost dock areas and put to sea. Land these troops at Beach B43-14 and march them to squares 42-14 and 41-14 respectively. This, coupled with 3d Arm Div's operation give you control of C 43-16.

Take 5th Arm Div from 29-50 and march it three squares on the road to C 28-51 and put out to sea. Land at C 43-16 and march around 3d Arm Div and across the river for a total of 6 squares to 40-15.

Drop 1st Para Div at 41-18 to protect your flank against a thrust across the river.

Finally march 4th Arm Div, 17th and 19th Inf Divs, and IV Corps HQ along the mountain road as far as possible. In arranging IV Corps area do it as per figure 1.

Afrika Korps—Tactics of Isolation

by Carl Knabe, II

I would like to introduce two terms relative to isolation in AFRIKA KORPS - single envelopment isolation and double envelopment isolation.

Single Envelopment Isolation - occurs when a unit is isolated by a band of control zones only one square wide at some point.

Double Envelopment Isolation - occurs when there are two (or more) lines of zones of control around a unit isolating it.

This rather technical distinction takes on importance when considered with the LOGISTICS rule of AFRIKA KORPS:

1. A Combat unit may attack only if the square it is attacking from is within 5 squares of a Supply Unit. The 5-square route must be unblocked by enemy zones of control.

And the definition under ISOLATION of a supply line:

A supply line is any line of squares one square wide (not under enemy zones of control) leading to a Supply Unit.

Now is states under ISOLATION that isolated units themselves cannot attach to break isolation, but the unstated corollary is that if a unit by placing itself in an attacking position (a 5-square supply route existing to that position) can show a line of supply then it can, in fact, attack, since it is no longer an "isolated" unit which is attacking. From this it becomes the object of the isolater, that if it is possible for the enemy Supply Unit to reach that position necessary for the isolated Unit's

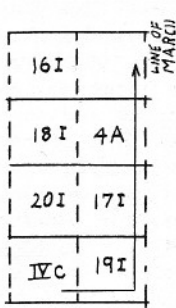

FIG. 1

Having done this march the 2d MtnDiv into the mountains at 36-32 to guard the passes and march the bulk of III Corps up to the riverline at 26 NS.

When all this is done you have completed Operation Long Romp I. This can be done in conjunction with or independently of Operation

Long Romp II which is below.

Long Romp II

This is an offensive operation against C 3-28.

Take 2nd Arm Div, at 16-35, and march it 18 road squares to 9-24 and then one off road square to 8-23.

Take 2nd Para Div and drop at 3-29. March through the city and then back to square 4-27 thus taking and garrisoning C 3-28.

"Launch" 6th Arm Div from C 28-51 after moving 4 road squares and land

(Continued on Page 8)

Midwest

Carl F. Knabe II
1244 State Street Courts
West Lafayette, Indiana



EDITOR - Midwest covering Wisconsin, Michigan, Illinois, Indiana and Ohio.

attack, to isolate the unit in such a manner that no matter where it moves there is no supply line.

The simple case of isolation is the triangular arrangement of units in diagram #1, the simplest case of single envelopment isolation in open country. However, if a supply unit is available, (or if the odds would be 1 to 3 or greater) then in order to assure destruction of the isolated unit double envelopment isolation must be employed. The most effective method of achieving double envelopment isolation is, of course, employing two concentric single envelopment isolations. Often this is not possible, however, and in this case (ex. German isolation of the British 2 Arm. 3 at Msus on the first turn of AFRIKA KORPS) the simplest method is a diamond shaped formation (diagram #2) using four units to create two lines of isolation at the same time.

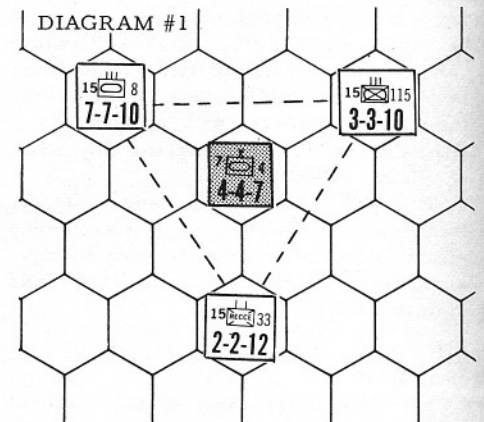

SINGLE ENVELOPMENT ISOLATION

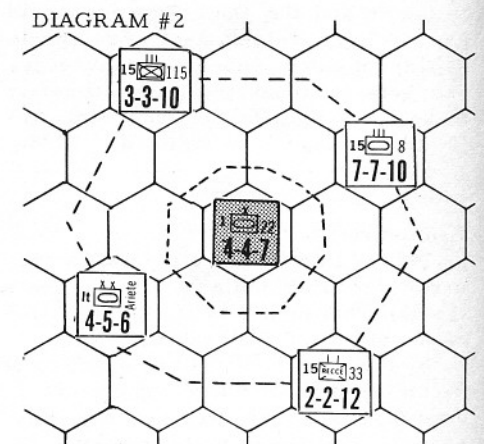

DOUBLE ENVELOPMENT ISOLATION

CONTEST NO. 4

This contest involves Football Strategy. YOU are the Quarterback as you attempt to crash through the solid defensive wall of our own "Avalon Hill Bledskins." All you have to do is select an offensive play for each of 4 downs. The object is to gain as many yards as possible.

Now - as the hulking forms of stellar linebackers Sam Rough, Steve Bonebreaker and Big Daddy Lipsplitter peer at you in disdain, get set for your first offensive play.

HOW YOU PLAY

Refer to the GAME PLAN chart. Under the Offensive Play column select one play for each down from among plays 1 thru 20 shown on the Offensive Plays From Scrimmage chart of your Football Strategy game. Indicate the 4 plays you select by number only. This is all you have to do. See the hypothetical example (A).

OFFENSIVE PLAY (select by number)	DEFENSE
5	COCA COLA
17	FORD MOTOR

(A)

HOW YOU SCORE

Yardage gains and losses will be determined in the manner similar to the way combat is resolved in the Play-by-Mail system: the judges will consult the N. Y. Stock Exchange report for closing transactions of Monday, December 7, 1964. The last digit of the Sales-in-Hundreds column for the Stocks that have been selected will be converted to the 10 basic defenses represented by letters A thru J. A last digit number of "1" converts to "Defense A", "2" converts to "Defense B", etc. with "0" converting to "Defense J." Each Defense will then be cross-indexed against each of the 4 Offensive plays to get the yards gained (or lost.)

HOW YOU WIN

Ten winners will be named. Winning entries will be those who gain the most yards in 4 downs. In case of ties, earliest postmarked entries will decide (allowances will be made for distant entrants.) Winners will be awarded a FREE Avalon Hill game of their choice.

HOW YOU ENTER

This contest is free to all subscribers. Simply fill in the GAME PLAN and mail to: The Avalon Hill Company, 210 W. 28th Street, Baltimore, Maryland 21211. Contest Dept. Entries must be postmarked on or before Saturday, December 5, 1964. Print your name and address clearly. And make sure that you mention the game you wish as winning prize.

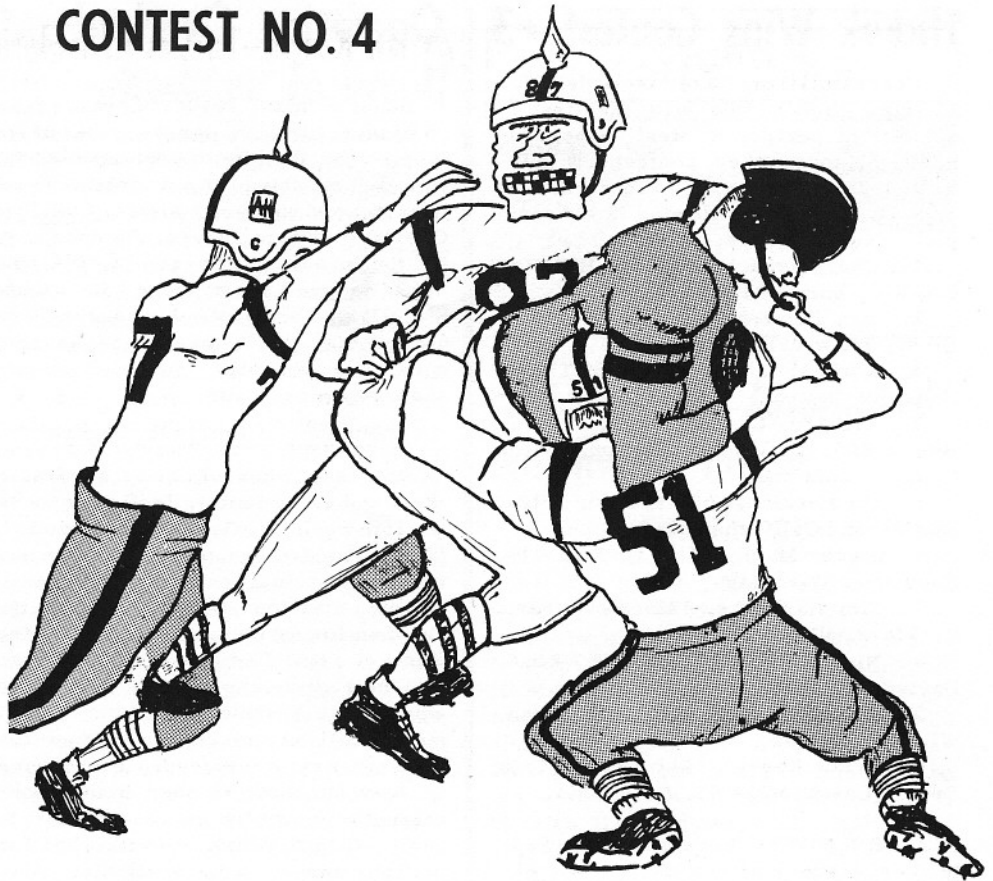

GAME PLAN

CUT HERE

OFFENSIVE PLAY (select by number)	DEFENSE	DO NOT MARK: AVALON HILL USE, ONLY	
	COCA COLA		
	FORD MOTOR		
	GENERAL ELECTRIC		
	I. B. M.		

CUT HERE

Name _____ PRIZE _____

Address _____

City _____ State _____

Hickok Wins Contest #3

Congratulations are in order for Charles Hickok who was the first to submit a perfect contest paper. In addition, four other contestants submitted perfect papers. Their entry is shown below. The following is the complete list of winners:

1. Charles Hickok, Windy Hill-Box 6, Harrisburg, Pa.
2. Dan Drewek, 311 W. Lexington Blvd., Milwaukee, Wisconsin.
3. Michael R. Childers, 3137 Tilfer, Houston, Texas.
4. Richard C. Lewis, Jr., P. O. Box 21405, University Station, Baton Rouge, Louisiana.
5. Gil Hoskins, 1604 Eleanor Drive, San Mateo, California.
6. Steve Mann, Rt. 2, Box 413, Cheyenne, Wyoming.
7. Jim Harkonen, 402 Shaw Street, Rockford, Illinois.
8. Nick Horning, 2822 Rugby Road, Dayton, Ohio.
9. Daniel Hughes, 1634 N. Sheridan, Wichita, Kansas.
10. Brian Berry, 1111 Linda Flora Drive, Los Angeles 49, California.

EDITOR'S NOTE: Because of the September issue mailing delay, we extended the deadline for this contest. We disqualified no one because of a late entry.

CUT HERE

Design Questionnaire

What is Avalon Hill's next game? Well, Avalon Hill's as much in the dark as you are. Their design staff has been isolated for over a month now and the best they've been able to come up with is, "COLISEUM", an exciting historical pursuit game. Unfortunately, it's balanced in favor of the lions.

Therefore, we must call upon YOU to make this decision for us. Listed below are game titles most often requested on the Registration Cards. We have listed them alphabetically so as not to influence your thinking. Please pick out three titles only. And list them by number; 1, 2 or 3 ... number 1 being your favorite.

- Ancient Greek Wars - involving Athens, Sparta, Corinth, Thebas, etc.
- Basketball Strategy - based on same principles of Football and Baseball Strategy games.
- Battle of the Bulge - The Ardennes campaign of World War II following the invasion.
- Bull Run - first battle of the Civil War.

Operation Overlord...

by Daniel Hughes

Since so many readers have expressed interest in the large game of the type I described in my last article, this time I shall devote my attention mainly to another of our large games, Overlord. Overlord was, of course, the code name for the invasion of France in 1944. You might say we have a souped-up version of D-Day. Since the board measures 60" by 50", there are more invasion squares, more mts., longer river lines, and many more units.

Number of Units Quadrupled

We have approximately quadrupled the number of units. In D-Day, after the 16th week, the Germans receive 5 replacement factors per turn. We have found the actual numbers of the new German divisions, so periodically new German formations appear in Western Europe. The German receive the actual new divisions in the order they actually were made available. This is more realistic, since not all new formations are motorized. The German is very hard put to keep his armored strength up, which was actually the case. He must make do with what formations happen to be available. About 50% of the new German divisions were static and Volksgrenadier divisions of low value.

Central

Daniel Hughes
1634 North Sheridan
Wichita, Kansas 67203



EDITOR -- Central covering North Dakota, South Dakota, Minnesota, Nebraska, Iowa, Kansas and Missouri.

The time period remains the same - one week. Against any German unit which is doubled or tripled, 2-3 or 13-24 counts as 1-1. 1-6 is necessary for soaking off. All fortresses triple. The West Wall is like fortresses in Afrika Korps. They double, and do not control squares adjacent to them. If they were not this way, the line would merely be another river line, which would be easy for the Allies to break. We allow the Allies to land after the 9th week in selected areas (Such as Biscay and South France.)

More Room for Maneuver

The board has about 100 invasion squares. There is one main line of (Continued on Page 12)

Discount Offer

The Coupon shown below is for the benefit of the full-year subscriber. As soon as you have accumulated 4 such coupons, 1 each from this and succeeding issues, you are entitled to a \$1.00 discount applied to the purchase of any Avalon Hill game.

Here's how it works

Each coupon is worth 25¢. But one coupon alone does not entitle you to a 25¢ credit. You must accumulate 4 different coupons before taking advantage of the \$1.00 credit. When you have accumulated 4 coupons, then you clip them all together and send them in with your order for an Avalon Hill game. When ordering in this manner, you simply send us a check or money-order for \$1.00 less than the usual retail value of the game.

Coupons are valid only when ordering games by mail directly from The Avalon Hill Company. Coupons can not be redeemed at any retail outlet.

25¢ **25¢**

SAVE THIS COUPON

GOOD ONLY WHEN APPLIED
TOWARD THE PURCHASE OF
AVALON HILL GAMES

NOV. 1964 NOV. 1964

CUT HERE

(Your signature)

Please send this Questionnaire to us as soon as possible. Your help is greatly appreciated.

Play-By-Mail League...

(Continued from Page 1)

printed exactly as furnished to our editorial office:

"The league itself will be composed of four distinct groups--C, B, A, and AA. The C group will be composed of all the individuals who have an average score less than 1.99; the B group will contain those individuals who have an average score between 2.00 and 2.50; the A group will be between 2.51 and 2.75; the AA group will be between 2.76 and 3.00. The average will be obtained by dividing the total number of points by the number of games played (three points for every win and one point for a loss). Since some of the games are slanted, the secretary will oscillate you between sides and, if possible, games. At the completion of five league games, your rating will be published in our bi-annual newsletter.

"Because of various difficulties, our game scope is limited to Stalingrad, Waterloo, D-Day and Afrika Korps. Incidentally, we supply the official coordinates.

"The only requirements for membership is the payment of a \$1.00 due, which is to cover the various cost (a complete record of expenditures will be in the newsletter) and the member agrees to play at least two PBM games a year.

"If you are interested in joining just send your dues and an index card with:

1. Your name, address and phone number.
 2. The list of AH games you own (of the above mentioned four).
 3. The game and side you wish to play in with your first encounter.
- In return, my office will send you:
1. A receipt for your dues.
 2. An official membership card with your number.
 3. An opponent.
 4. Regulations and additional information.

Our address is:

Avalon Hill Wargamers PBM League
Box 572
Huntington, Indiana 46750

Naval Affairs

(Continued from Page 2)

listening should be required to proceed at 1/2 speed or less. If visibility is assumed to be good enough to cover the entire board area, moves may be made submerged by means of secret recorded notes, and a separate board system would no longer be needed. However, as often happened in the North Sea and North Atlantic visibility was reduced and accordingly in the days prior to the introduction of radar some sort of concealment method should be arranged, that is if you want this added realism.

Meanwhile - - Back at Tactics II

After I had played Tactics II about ten times the game began to seem too simple to me. I felt this way because the game just didn't seem to have enough units.

The first thing I did was double the number of divisions. Since I didn't have the extra set of counters, I used divisions from D-Day until I could get another set of counters. Later on, when I received another set of counters I decided to try adding them to the game. I gradually phased them into the game by adding one armored, two infantry, and one specialized division per replacement period.

Another innovation of mine was the introduction of three entirely new types of divisions to Tactics II. The first of these was a division I labeled heavy armored. This division would consist primarily of tanks on the order of the German Tiger Tank. It has a combat factor of five and a movement factor of four, it can cross rivers only at bridges and, of course, cannot travel in forests. If it is somehow lost you must wait until your next replacement period and then count nine months.

The second unit is the armored infantry, of which there are two. It has the same restrictions as the regular armored division, except that it has a combat factor of three and a movement factor of six.

The third unit is the motorized division, of which there are also two.

(Continued from Page 12)

The Element of Surprise

(Continued from Page 3)

Prussian Corps arrive by the primary road on the eastern board edge and French II Cav Corp must also remain E of Chaleroi. Another idea related to this one is changing the blocked road rule. If a road is blocked, the arriving units come through the nearest unblocked sq.

TACTICS III

The general opinion around here is that Tactics II is one of the worst A. H. war games. For a possible improvement try these changes:

1. Four Units of any type are allowed to a square.
2. Automatic Victory.
3. Victory is achieved if you control more than half the enemy cities for three consecutive turns (Industrial capacity would be shattered).
4. Moving 2 sqs diagonally equals 3 sqs of normal movement.

Northwest

Philip Beasley
522 W. 2nd Street
Libby, Montana



EDITOR: Northwest covering Idaho, Montana, Wyoming, Nevada, Utah and Colorado.

History Buff Appointed Northwest Editor...

Although I am only 15 years of age and will only be a Sophomore in the 1964-1965 school year, I feel that I am qualified for the position.

I was born in Spokane, Washington in 1949 and lived there for two years until my family moved to Libby, Montana. I have participated in baseball, football, and track. I bought my first Avalon Hill game, "Gettysburg" in 1961 and since then have acquired: D-Day, Tactics II, Bismarck, and Stalingrad.

I have read many books on military history, covering all the major campaigns of the Revolutionary War, Civil War, World War I and II and Korea. My columns would be written with the purpose of examining campaigns fought in your games and writing my opinion on their execution and planning and telling of alternative plans and my opinions of them.

5. Isolated Para units can not take off.

D-DAY

Presently an infantry unit in Waterloo can move more than twice as much as an armored unit in D-Day. Try doubling all movement except during the invasion turns.

SEA WAR

Even with my limited knowledge of naval war games, it seems to me that a pretty great game might be devised if all the ships in Bismarck were divided into two navies, not necessarily numerically the same, but equal in their abilities to sustain combat.

I suggest splitting the cruisers and carriers into two equal forces. Bismarck, Hood, Ramillies, Repulse would make up the rest of one force; while the remaining capital ships, the other. Force A would start at H-6, and force B from A-6. Both sides fight to the last ship.

Well so long for now. There's about twenty tanks outside and I hear some mumbling about AFRIKA KORPS.

How to Win at Word Power Without Increasing Your Vocabulary . . .

by Louis Zocchi

There will be times during the game when you will be required to play something you don't have. Let's say you are required to play a synonym when you have none. If there are no cards in any of the windows, you are faced with paying a \$2,000 fine or playing an antonym. Play the antonym. You might skate by unnoticed. If you are caught, you will lose \$1,000 but you still saved \$1,000.

It's your turn to play, and there is a card in the first window. In your hand you have a choice of cards. Let's say that you don't have enough cards to fill all the windows but you could fill windows #1, #3, & #4. You should play the card that fills in window #1. If you play all 3 cards you set up the next player. All the next player has to do is play the card for #2 window if he has it and he gets a book. Why help him at all? If you play your #1 window card

the window situation is passed on to the next player and you haven't helped him at all, but if he covers any window other than #1, he has helped you.

Avoid Setting Up The Next Player

Lets say that there are 2 windows filled and it is your turn to play. In your hand you can fill in the 3rd window with one of your cards and the others are no help at all. If you think that one of the players to follow you will be able to supply the card required to fill in the 4th window, you might be wiser to play a card that is completely wrong in a box that is already filled. You will probably lose \$1,000, but you will also refrain from setting up the next player. If you can afford the loss of money, you will be in a better position to complete the book yourself. When you play cards that you know are wrong just to avoid setting up your opponents, it is best to play the words you don't know or words that don't match up with the

Southwest

S/SGT. Louis Zocchi
CMR #2, Box 5600
Keesler AFB, Mississippi



EDITOR - Southwest covering Arizona, New Mexico, Texas, Oklahoma, Arkansas and Louisiana.

open window. This way you might draw a card you are more familiar with or you might draw a card that could fill in a blank window.

Club vs Club Combat

Tommy Turner of 3110 Hamilton in La Porte, Texas has asked me to mention that he has formed a wargames club and would like any Texans living near La Porte to contact him. Tommy would like to engage in Club to Club combat so if you people who already belong to clubs will write to Tom, I'm sure he will appreciate it.

Avalon Hill Phantom

(continued from page 1)

color there is and it's luminous sparkle enables it to be seen from long distances.

The Decals are easy to attach to surfaces. No gluing necessary. A self-adhesive coating is printed on the back of each. All you have to do is peel the paper backing; press to a surface . . . and then run.

Where should you put them? We'll let that up to your imagination. All we know is that these wallet-size Phantom Decals have appeared on envelopes, school books, even restaurant menus. The Phantom measures 2 1/2" x 1 1/2".



Once you've gained a little "combat experience" you can do additional "infiltrating" with the larger sizes: there's nothing like Conspicuous consumption which is what Baltimoreans are saying about the 7" x 10" size they have seen attached to car bumpers and church pews. The next size up, the Jumbo, is 15" x 22". We don't make any recommendations here nor can we suggest where to put the Blinder, our giant 22" x 30" Decals that have made their surreptitious appearances on trucks and condemned house walls. (NOTE: we'll



GADZOOKS! THE PHANTOM HAS STRUCK AGAIN!

print the name of the subscriber who gets one on a jet airliner.)

We'd like to be able to give them away. But we can't. First, to make it easy for you, we have applied the adhesive backing which is a very costly process. Secondly, we want to limit the distribution of the Decals to only those of you who have purity of purpose and will be discreet in where you put them.

All prices are post-paid. Decals sent to you first class mail.

The Phantom 50 for \$1.00
The Conspicuous 4 for \$1.00
The Jumbo 2 for \$1.00
The Blinder 1 for \$1.00

You may order in unlimited quantities but the minimum order must be for \$1.00. Enclose a check or money order and mail to: The Avalon Hill Company, 210 W. 28th Street, Baltimore, Maryland 21211. (Actually, the Phantom is somewhere else and only the postman knows.)

The Long Romps!

(Continued from Page 4)

it at C 3-28. March to 7-23 and 2nd Arm Div's flank.

Take 16th Inf Div from 36-46 and march 6 road squares to C 43-43. Put to sea and land at C 3-28's easternmost dock area and march 9 road squares to 8-24 and 2nd Arm Div's other flank.

Then take 1st Mtn Div and march 9 squares from 14-42 to Blue Capital's nearest dock area and put to sea. Land at C 3-28's central dock area and march to 6-24 thus protecting 6th Arm Div's flank and preventing Red from slipping through the pass at 4-23.

Having done this march the bulk of I Corps towards C 3-28 excepting one Inf Div which should be detached to guard the road paralleling 10 EW.

Finally move II Corps up to the riverline at 26 NS and concentrate the divisions remaining in the rear (18th, 20th, 21st, 22nd, 23rd, 24th, and 25th Inf Divs) at the various ports to prevent a Red landing in your rear while you're slicing up his territory.

The "Long Romps" leave you in possession of a fine jump off line for your next few turns which should be aimed at cutting the Island off from the rest of Red territory and trapping the major portion of Red's army on the mainland.

The beauty of this plan is that pure maneuver has been used to put Red off balance. For anything up to three turns Red will be unable to reply adequately to you and by that time it could be all over if you press your advantages.

Herbert Stern and His Aluminum Foil Combat Results Table

by Herbert Stern

It was with considerable interest that I read Martin Leith's article on the electric combat results board. In addition to my interest in your games, I have also been a model railroader for a number of years, and so I have quite a lot of electrical odds and ends lying around. After some experimenting I believe I have improved on three shortcomings of Mr. Leith's board.

Mr. Leith used three keys on each side. This gives nine possible results, thus making some combinations more likely than others. I give the attacker two keys and the defender three; this results in six possible combinations - one for each side of the die. For the actual construction of the keys, I took some old relay contacts from my junk drawer and arranged them into two TPST and three DPST switches with each leaf insulated from the others when in the OFF position.

With this switch set-up, I can now wire the results board to six bulbs rather than three. These bulbs I set right into the results table on the cabinet (a cigar box) in the 1-1 row. For bulbs I used 12 volt grain-of-wheat

bulbs which are available in any hobby shop; I found that red bulbs show up best. For power I used a 9 volt No. 216 transistor radio battery because it does not overheat the bulb filaments and it is a very small, easy to manage battery.

Finally, I felt that with just one circuit possibility the players would soon learn the most advantageous keys to press, and there would soon be only one or two possible results in any given situation. To alter this, I connected the wire leads from the switches and light bulbs to brass studs on the inside of the cabinet. Next I made up cards which could be placed inside in the right spot by means of two wooden posts in the box which fit through holes in the card. I glued aluminum foil to the card which carry the current between the proper contacts; the appearance of the card is much like a printed circuit which would easily lend itself to commercial possibilities. I have a number of these circuit cards. Before a game they are shuffled, and for every turn a new card is used. A rubber band arrangement keeps the card firmly pressed against the contacts.

Those with comments may write me at: 88-35 196th St., Hollis, New York 11423.

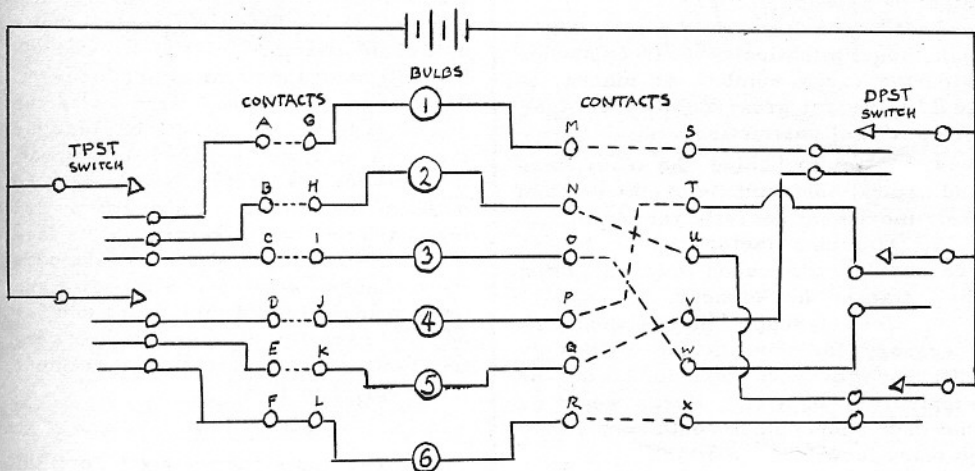

---- DOTTED LINES ARE THE ALUMINUM STRIPS

More Realism in Tactics II

(Continued from Page 10)

in Europe and the Pacific from the air and land to the sea. The fabulous pictures in these books are some of the best ever.

5. The Guns of August by Barbara Tuchman. Excellent account of the events that led up to and occurred in the first month of WW I.

Tip of the Month

To incorporate the play-by-mail

odds table in regular play, simply roll the dice twice. The first roll would determine if the number would be odd or even. The second toss would tell you which of the five possible combinations you've rolled. Example: 1st roll 4. This means your number will be even. 2nd roll 3. The third even number is 6. In the event that you roll a 6, on the second roll, you'll have to roll again. Many thanks to Ron Siskind, 945 Gayley Ave., Los Angeles for his tip. If you have ideas that might make good suggestions, send them in!

Arctic

Martin D. Leith
Box 623, Quesnel,
B.C., Canada



Really now, I may be a bit North, but I'm not in the Arctic. I'm over 2000 miles south of the Arctic. Avalon Hill, take notice.

I wear ordinary clothes - not a fur suit, there's steak in the 'fridge - not whale blubber, I live in a stucco house - not an igloo, and I drive a big fat convertible - not a dog-team.

EDITOR'S NOTE: you're also just about the only Avalon Hill player in those 2,000 miles consequently you're it for the entire northern hemisphere. but thanks for the geography lesson.

First comments on the '64 version of Gettysburg:

I don't agree with the "no movement delay" in the game.

The Civil War has been one of my favorite eras of history for as long as I can remember, so from one of my books on the war, entitled "The Civil War" (Hansen) I would like to quote a few references to the Gettysburg battle which should point out why there should be movement delays.

"Cemetery Ridge is lost in sloping country heavily loaded with rocks and boulders."

"The 15th Alabama had an arduous climb up the less exposed sides of Big Round Top."

"The Brigade of Brig. Gen. E.M. Law struggled up the craggy slopes of Little Round Top, dodging among boulders."

Peach Orchard and Devils Den - which are not shown on the board - are described as terrain so difficult that only manual strength could move the guns over the huge crags.

In the game, if I have an artillery unit in square 18-15, I can go merrily up, over and down Cemetery Ridge at full movement factor.

I feel it is logical to assume that to take artillery over such terrain at full gallop, in real life, would have resulted in injury to horses, guns and caissons having shattered axles and wheels, and gunners being thrown in all directions.

The same should hold true for going through the wooded areas, what with guns bouncing over dead-falls and gunners being whacked on the chops with branches.

And, can anyone imagine a cavalry charge through woods? My imagination conjures up a picture of a trooper dangling by his chin from a low hanging

(Continued on Page 11)

Question Corner

Afrika Korps;

Q: Suppose a 7-7-10 Unit is completely surrounded by 1-1-6 zones of control and there is no Supply Unit within the encirclement, can the 7-7-10 Unit attack out?

A: Yes...because once the 7-7-10 is moved against a 1-1-6 Unit, there occurs an automatic victory situation which immediately negates that 1-1-6's zone of control thus providing a supply path to an outside Supply Unit.

Tactics II:

Q: What is the Replacement Center?

A: Both Blue and Red Countries have replacement areas so marked close to their respective capital cities.

Q: If a Unit is attacked from across the river and clear terrain, is it doubled?

A: No.

U-Boat:

Q: Can a damaged U-Boat enter the convoy zone if it is submerged?

A: No, because a damaged U-Boat (one that has sustained one near miss) must surface and cannot submerge again. Thus a damaged U-Boat cannot enter the convoy zone and must sink the DE to win the game.

Stalingrad:

Q: If a Unit is attacked from across a river and along the same river is it doubled?

A: Yes.

Q: Can Italian and Hungarian Units be placed in Finland?

A: No. No additional Units can be placed in Finland after the first Turn.

Q: Can Units be placed next to the Hungarian border on the first turn?

A: Yes.

Q: Do defending Units get doubled defending behind the Lug, Volkov or Sivv rivers if they are on a swamp square?

A: Yes.

D-Day:

Q: Is there any limit to the number of replacements the Germans can get in D-Day?

A: No. While you are restricted to 5 attack factors per week, they may be accumulated. Any German Unit may be used except HQ Units.

Q: Are Rotterdam and Amsterdam considered coastal land squares? And if so, is it permissible to place static divisions in them to receive the first invasion?

A: No, these ports cannot be invaded by sea on the invasion week.

(Continued on Page 12)

Putting More Realism into Tactics II

by Jon Perica

If most of you are like me, after a while, playing Avalon Hill games seems to become less challenging in the sense that the movements in each game become almost automatic.

Therefore, after quite a bit of thinking on the matter, the members of the Committee for Games Improvement and Development have come up with 12 suggestions that they hope might be incorporated in any future games Avalon Hill develops.

Several of these ideas are found in part among other AH games, but the committee has gone a little bit further in their development. Although these suggestions could be applied to almost any game on any topic, they were specifically created for a modern warfare type of game similar to Tactics II.

1. Approximately equal sides with the only difference, if any, in the types of pieces. The total number of factors for both sides would be even.

2. Use of a lot of units, between 300-350 as an example if large factor pieces were used, would provide many chances to attack and counterattack. With smaller factor pieces, the total might be between 225-275.

3. No real object in the game other than the elimination of your opponent. With the large number of pieces, it would allow for great mobility because of the lack of restrictions.

4. All units behind the main lines and natural obstructions are hidden and their movement secretly recorded.

5. Attacking factors would be increased depending upon which direction they attacked the defender.

6. Use of supply pieces would be necessary for any attacks. The only difference between this idea and the supply rule in Afrika Korps would be that each supply piece could supply only so many factors in an attack.

7. Bridges and railroads could be destroyed by engineer units in one turn. To repair the damage it would take one turn also, but actual movement would have to wait until the second turn.

8. All units could 'see' several squares ahead of him. This is where your small recon units would come in to play by probing enemy positions and build-ups.

9. Artillery would have a range greater than one square. To counter this advantage, the defense factor of the units would be very small.

10. Slight change in the odds table to allow odds of 6-7 or 10-12 to be rounded off to 1-1.

The next two suggestions go hand in hand and represent the most far reach-

Pacific Coast

Jon Perica
5663 Ramara Avenue
Woodland Hills,
California 91364



EDITOR -- Pacific Coast covering Hawaii, California, Oregon, Washington and the Far East.

ing and important changes suggested by the committee.

11. Complete changes in the odds table. Instead of exchanges and eliminations, the table would simply say defender loose 3 combat factors and retreat 2 squares, or attacker loose 4 factors and retreat 3 squares. The reason for such a drastic change would be to bring about a true realism not found in the present odds table. Even if a unit is badly defeated, it is very unlikely that it would be totally destroyed. Before this happens, the attacker or defender would usually break off the engagement. As it is now, the loss of part of your men completely eliminates your entire piece.

12. All units engaged in a battle would loose at least one factor by simply fighting. This takes into account the losses that every attacking unit occurs. It hardly seems logical that a unit could attack 3 times at 1-1 and win but still have the same attack strength. This suggestion would also make the use of reserves necessary because the longer a unit was engaged in combat, the smaller its factors would be. To build up lost factors, every 2nd or 3rd turn each unit would regain 1 of its factors. This change, along with the odds table changes would make it easier and more profitable to attack at 1-1 and 2-1 odds. In reality, it seems that in very few battles did the attacker outnumber the enemy 3 to 1.

Book List

1. The Land They Fought For: the Story of the South as the Confederacy by Clifford Dowley. Many books have been written on the Civil War, but none have viewed our great conflict from this aspect before.

2. Rommel, the Desert Fox by Desmond Young. In my opinion, best biography of the great German commander ever written. Read how Rommel's Volkswagon tanks tricked the English.

3. The U. S. Navy in WW II by Morrison. Complete series of volumes that deal with the battles at sea on both fronts.

4. Illustrated Military History of WW II. 14 volumes that cover the war

(Continued on Page 9)

Limited Intelligence Game

(Continued from Page 3)

maps, what units the armies will be made up of, even how many players the game will involve. All that need be said about the maps is that (a) each player should have one and there should be one extra; (b) the maps should be hexagoned - with a grid identical to the extent that the same physical features would occur in corresponding squares; (c) since this game involves both campaigns and battles, the boards must be fairly large. As for the units, each player must have a complete set of his own troops and his opponents'. In my personal game I have organized the units after the French Revolutionary system.

Arctic (Continued from Page 9)

branch while his mount goes rambling on alone.

I would like to suggest that all movement be reduced to one square per turn when going through a wooded area - unless units are on a road.

Also, unless a unit is on a road, it must halt when reaching a ridge and proceed over the ridge at one square per turn.

When on the ridge, and moving in a North-South direction, movement could be at full factor.

Only the heavily shaded ridges and hills need be affected by the "crossing" suggestion.

These would be Herr Ridge, McPherson Ridge, the north tip of Seminary Ridge, Cemetery Ridge, Cemetery Hill, Oak Hill, Benner Hill, Culps Hill, Wolf Hill, Powers Hill, and the Round Tops.

I would further suggest that Peach Orchard be located in square 20-10 and Devils Den be located in square 23-10, and the area between these two points east of the Emmitsburg Road and over to the East fork of Plum Run be marked as the "craggy" area, therefore requiring movement of only one square per turn.

It is felt that this would make the game more interesting and more challenging.

Comments on this, either "for" or "against" would be appreciated.

EDITOR'S NOTE: True to an extent. However, because of the smallness of scope of this battle area, movement factors were reduced to begin with. Actually, at normal speed any Unit could have covered the entire battlefield area in the space of 1 hour.

In closing, I would like to remind Canadian readers that this isn't "my" column - it's "ours", so if you have ideas, suggestions, or beefs let's have them.

The organization of the game involves each player being out of sight of the others. With the extra map that I mentioned there is a Control Figure. He has before him constantly the dispositions of all the units of all the players, and he coordinates things.

A. Observation. Here the limited-intelligence principle comes into direct bearing. Each individual player is the commander-in-chief of his troops, sitting in a Headquarters with a map in front of him. What he sees on that map is the sum total of the reports sent him by his troops, scouts and spies. Now assuming this, it is obvious that he cannot see all of his enemies' dispositions. At the end of each turn, each player sends to the Control Figure the dispositions of all his forces, and before the beginning of the next turn the Control Figure sends back a report of exactly what enemy units the player's sources know the locations of.

Scouts move with the troops, and affect the play only in that they mean that a body of troops always knows what is happening within a certain distance all around; that distance depending on the scale map you're using.

Spies are for more long-range work. Commanders are assumed to know what goes on in their own countries (through loyal peasants, etc.) But each player is allowed to know something of what goes on behind the lines in enemy countries as well - through spies. The player is given a certain acreage that

his spies cover, as it might be fifteen squares. He could choose to cover fifteen different cross-roads or bridges, which he would tell the Control Figure of, so that, whenever there was any enemy movement through those squares, he would learn of it from the Control Figure. There would be the danger of the enemy skirting those squares, so he might have five groups of three adjacent squares being covered, or three groups of five, or one group of fifteen for that matter. If a player knows where an enemy's spy is, he names the square exactly to the Control Figure; if he is right, then that spy is shot, and his owner must wait four turns, to train and establish another spy, before replacing the dead one. Each player has an unlimited number of guesses, whether he is right or wrong, but he should only be allowed to make a limited number each turn, like say one or two. If he guesses and is wrong, the owner of the spy in question is informed of the guess, and what square(s) are involved. Spies may move, but one turn must elapse between the turn they leave one locality and the turn that they become effective in another.

AH NOTE: The second and concluding part of this article, containing info on movement, combat, supply and other variables, will appear in the January issue.

OPPONENTS WANTED

EDITOR'S NOTE: As a free service to the subscriber, we will publish any "Want Ad" submitted to us. Please type your "Ad" and word it exactly as you wish it published. Ads received after the 15th day preceding publication date will appear in the following issue.

Wanted: Opponents in D-Day, Tactics II, Waterloo, Gettysburg, Management. Contact Das Kriegsspiel Bund c/o Stanley D. Hoffman, Bexley 306, 50 Massachusetts Ave., Cambridge, Mass. 02139. I am a sophomore at Massachusetts Institute of Technology.

28 year old H.S. math teacher seeks worthy opponent. No by-mails. 30-0 record all games. MENSA William Gilbert, 37 Spruce St., Great Neck, N.Y. 11021

FROM: Stanley D. Hoffman, age 18, President - The War Games Club Headquarters - Massachusetts Institute of Technology, Address: Bexley 306 50 Massachusetts Ave., Cambridge, Mass. 02139.

TO: Any experienced Avalon Hill gamer of high school level or greater.

SUBJECT: Your defeat by my undefeated and invincible general staff or any part of it in any Avalon Hill game capable of being played by mail. We prefer Germans in D-Day and Stalingrad, French in Waterloo, Red in Tactics II, we also play Management and Air Empire.

A 'brain trust' staff of 16 players wishes to challenge any opposing player(s) to a play-by-mail game of AFRIKA KORPS. Opponent may choose either side but must be experienced if wishes to last six months. Staff correspondent William H. McCabe, 2795 Coleridge Rd., Cleveland Hts. 18, Ohio.

Afrika Korps, Waterloo, D-Day, and Stalingrad opponents wanted. Experience necessary. I prefer non-radical, anti-leftist challengers. Write: Michael McCabe, 1460 Sunset Strip, Fort Lauderdale, Florida 33313.

Opponents needed for Afrika Korps either side, mail answer to: Bruce T. Klem, 2463 So. 80th St., West Allis, Wis. 53219.

I have a record of 26-4, and would like to improve it. Anyone who wants to take these sides in the following games is welcome to try and beat me. Gettysburg (1958) - North; Chancellorsville - North; D-Day-Allies, and Bismarck-British. Include in your first letter your rules and/or suggestions. Write: John Rockholz, East Rocks Road, Norwalk, Connecticut, 06851.

Will all those interested in joining a SAN FRANCISCO and BAY AREA Avalon Hill game club please send a letter, with the game you own and your address to: Jack Greene, Jr., 670 Darrell Rd., Hillsborough, California, 94010.

The undefeated General Staff of Das Kriegsspiel Bund is looking for any Allied Generals who thinks they can crack our impregnable defense in D-Day. If you are among those who cannot stand defeat then you should not write: O.B. West Das Kriegsspiel Bund, 126 Washington Hwy., Snyder, N.Y. 14226.

Army commanders wanted for multiple-player game of D-Day (6 or more participants). Those interested contact James W. Connelley, 3556 Oak Leaf Rd., Pittsburgh, Penna. 15227.

"Achtung! Will play Afrika Korps against any willing British generals. Please specify rules that you wish to play under. Write: E. (for Erwin) Ossa, 12 First Ave., Pelham, N.Y." I play Tactics II, D-Day, Afrika Korps, Chancellorsville, Gettysburg (old version), Stalingrad, and Waterloo. Victims needed, write: Richard M. Robertson, 916 E. Beckwith P-10, Missoula, Montana.

Capable Southern General would like to challenge any Yankee in a game of Gettysburg ('64 copyright) or Chancellorsville. I also will play all other A-H land battle games. Write: Brian Berry, 1111 Linda Flora Drive, Los Angeles 49, California.

Do you have a club? Are you a member of one? If so please reply to this challenge from the TACTICS AND STRATEGY CLUB OF CALIFORNIA. You pick the game and side. TACTICS AND STRATEGY CLUB OF CALIFORNIA, 20624 Skouras Drive, Canoga Park, California 90136.

How about an invigorating game of AFRIKA KORPS, GETTYSBURG, or TACTICS II. Write: George L. Phelps, 20624 Skouras Drive, Canoga Park, California 90136.

Unmerciful German Field Marshall from the "City of Brotherly Love" wishes to do battle with anyone who wants to send Allied troops to their doom on the sands of North Africa. Contact: L. Diernback, 622 E. Westmoreland St., Philadelphia, Pa. 19134.

Singles or teams. Play-by-mail for ALL games. Write to Jack Greene, Jr. and/or Steven Karel, 670 Darrell Rd., Hillsborough, Calif. 94010. Remember the tactics of 1834.

Anyone in Pittsburgh area interested in forming an Avalon Hill Club please call or write: Douglass Burke, 1108 Hiland Ave., Coraopolis, Pa.

SEIG HEIL! Wanted...a sucker (oops), I mean a British opponent for Afrika Korps or (your choice of sides) Tactics II. Would like to contact anyone in Austin, Texas area to play any A-H game owned... GR 7-1864, or write: "Generalfeldmarschall" Jim Kirk, Box 58, A-Bar Hotel, Austin, Texas.

Undefeated player wishes to meet and play any player within a reasonable distance. Will play any war game, Phone 259-6026 (area code 203). James Langefeld, 343 Old Hickory Road, Fairfield, Connecticut.

Operation Overlord...

transportation, which can be rendered ineffective by the Allied Air Force. There is more room for maneuver, but sooner or later the Allies must face the formidable West Wall. Rivers and river rules are the same as in Stalingrad.

We have found a new way of making troops of very high quality. We were forced to, since we need units with factors not produced by AH. The basic unit is the Regt. The British equivalent is the Brigade. Germans:

Pz. Dv.	4 Pz. Gd. Regt.
Pz. Gd. Dv.	3 weak Regts.
Static	3 Inf. Regts.
Infantry	1 Recce Batt.
2 Pz. Rgt.	1 Recce Batt.
1 Pz. Gd. Regt.	1 Recce Batt.

American Divisions have three R. C. T.'s or Combat commands depending upon type. British divisions have armored brigades and infantry (mot.) brigades. There are also several German independent Panzer brigades and two Mtn. divisions. Even 2 Italian divs. get into the act. Allied units are blue or green, Germans yellow or Red, and Italians are White.

Game is Balanced

Since the board was completed only a few days before school began, only games have been played so far. The Germans won the first, and the Allies the second. We all agree that the game is very well balanced. The only problem is that it takes at least 1 1/2 days to play - and preferable two. It is difficult to find two days when we have enough time to play the full game. I am anxious to hear from the readers and will supply requested information.

Letters, Yes We Get Letters...

(Continued on Page 3)

that air fields and spare planes could be dropped with airborne troops.

You should have told this to the British and American airborne divisions that tried to capture the bridges around Arnheim and Aachen during WW II. They would have been glad to "fly away and escape." Unfortunately, those who weren't rescued by Allied armored units got stepped on and squashed!

Fly away and escape — giish!!!
...Larry G. Willey

EDITOR'S NOTE: This rule in D-DAY is a symbolic liberalization to keep it uncomplicated. Whole divisions are not lost in the real battle in one "roll of the die" either...but that's the way you must play the game.

Back at Tactics II

(Continued from Page 7)

This division is replaced as a specialized division and has a combat factor of two and a movement factor of nine. Otherwise they are the same as infantry.

The last major alteration of mine is to the board itself. I added three new cities to the board, two blue and one red. With the increased number of divisions this is necessary to keep things equal. The red city is on squares 28-3, 28-4, 29-4 and 30-4. The first blue city is located on squares 11-55, 11-54, 10-54, 9-54, with 10-55 a sea square. The second blue city is located on squares 2-41, 3-41, 3-42, 3-43, 2-43, with 2-42 a sea square.

As far as replacements go you simply double each city's replacement capacity. Thus each capital returns two armored per replacement period, etc.

I would appreciate your comments and suggestions on my ideas.

SUBSCRIBER DIRECTORY

Add the following to your Directory of Names printed in previous issues.

Arizona

WILLIAM D. VASKO
4442 Bryn Mawr Rd., Tucson 85711

California

JON PERICA
5663 Ramara Ave., Woodland Hills
NICK WISHEK
7042 Stanton Ave., Buena Park 90621
FRED A WEBSTER

844 Ashcomb Dr., Valinda
ROBERT CASEY

503 E. Myrtle, Hanford
ENS. R. REDDOCH, U.S.N.
2646 B Springs Rd., Vallejo 93
FRED JACOBS

16 Cortsen Ct., Pleasant Hill
PATRICK MILNE

7137 S. La Cienega Blvd., Los Angeles
WILLIAM CARPENTER

301 Alma Real Dr., Pacific
RONALD SANFILIPPO
8658 E. Grand Ave., Rosemead 91770
MR. AND MRS. JAMES LEE MATHEWS
4482 Muir Ave., San Diego 7

CARL B. SLABAUGH
3906 La Cresenta Ave., Montrose 20

Colorado

HAROLD HOCK
P.O. Box 731, Alamosa 81101

Florida

DR. M. SMITH
512 Washington Ave., Miami Beach

Georgia

GARY LANHAM
Illinois

JAMES F. MALONEY
1221 N. Ninth Ave., Melrose Park

PHILIP A. SMITH
310 Spelter Ave., Danville 61833

ROBERT OLSON
c/o C. W. Olson Co., 175 W. Jackson

Bldv., Chicago 4
LARRY A. GARNER
R. R. 1, Mulkeytown

Kansas

DANIEL HUGHES
1634 N. Sheridan, Wichita 67203

LARRY FILA
2404 N. Jackson, Hutchinson

Kentucky

CAPT. ARTHUR T. CAREY
5461-F Lowe St., Fort Knox 40122

Louisiana

CHARLES B. THOMAS
P.O. Box 53223, New Orleans 50

TRAVIS TYNES, JR.
500 Moore Ave., Monroe

Maryland

HILARY SMITH
7805 Maple Ridge Rd., Bethesda 14

JAY W. ROCKSTROH
2915 Pennsylvania Ave., Baltimore 27

Massachusetts

MICHAEL G. CASEY
21 Rockingham Ave., Lowell

WILLIAM J. CRONIN
115 Coleman St., Malden

ALAN CARLSON
Sawmill La., Sudbury 01776

L. A. GOULD

85 Leland Rd., Chestnut Hill 02167
LEONARD CAWLEY, JR.

13 Marlborough Rd., Salem 01970
Michigan

STEPHEN J. WASZAK
6426 Oakman Blvd., Detroit

ROBERT M. LUTON
540 Rosewood S.E., Grand Rapids

R. R. BERRY
24909 Carlyle Ave., Dearborn

RICHARD DALTON
201 North Ave., Battle Creek

Minnesota

TONY PAXTON
114 Arthur S.E., Minneapolis 55414

JOHN SKOLTE
Route 3, Box 195, Austin

BILL SOULE
14813 Lloyd's Dr., Minnetonka 53345

Montana

RICHARD M. ROBERTSON
916 E. Beckwith P-10, Missoula

New Jersey

R. S. LIEBL
70 Pinetree La., Willingboro

ALLEN YOUNG

501 Fairway Rd., Linden

DANIEL KELLY
377 Newtown Rd., Wyckoff

FRANK J. PLANER
12-45 River Rd., Fair Lawn

HENRY H. BODENSTEDT
86 Manalapan Ave., Freehold

LEW MITCHELL, III
8 Lee Pl., Basking Ridge 07920

New York

DAS KRIEGSSPIEL BUND
THE WAR GAMES CLUB
126 Washington Hwy., Buffalo 14226

ARTHUR ALONZO
5012 Fourth Ave., Brooklyn 20

STEPHEN GEISINGER
1475 Wythe Pl., Bronx 52

LEONARD PEDERSON
c/o SFC Bernt S. Pederson
"A" Brty, 1st MS1 Bn., 60th Arty.,

APO 175, New York, N.Y.

JAMES P. REYNOLDS
253 Sunrise Hwy., Rm. 405, Rockville

Centre

THOMAS D. BOWIE
American Embassy, APO 794, N.Y.

JACK HOTCHKISS
71 Falconer Street, Frewsburg 14738

North Carolina

WALTER G. GREEN, III
P.O. Box 621, Burlington

Question Corner

Q: The instructions say that if a unit in the first wave of an invasion is unopposed, it moves ashore and if it, then, is adjacent to an enemy unit it must attack. Does this mean only adjacent normal squares, or does it include units behind rivers and forts?

A: Only adjacent, non-doubled normal squares.

Q: If a unit is defending behind a river and the river runs along 4 sides of the square the unit is on and the unit is attacked from these 4 sides and is forced back 2, can the unit retreat across the 2 open squares which under normal circumstances would be under enemy control from the attackers? When a unit attacks across a river, is it considered that the river isn't there except that the defender is doubled?

A: Yes, the Unit is allowed to retreat across the 2 open squares. No, to the second part of the question.

Ohio

RALPH HERBERT
639 South Kensington Rd., Cleveland

FREDERICK TYLER, JR.
3475 E. Boulevard, Cleveland 44104

MIKE TSCHAPPAT
1689 Rushton Rd., Cleveland 44121

SAM KANAI
3227 Center Dr., Parma 44134

DAVID B. TOWELL, JR.
P.O. Box 62, Frankfort

JAMES HEATON
3411 Alexis Rd., Toledo 43623

JOHN A. BRYCE
Leader Enterprise, Montpelier

THOMAS B. BECKER
539 - 32nd St., N.W., Canton 44709

Oklahoma

HENRY R. ADAMS
1431 W. Hayes St., Norman

MIKE MORRISON
302 B Iroquois Trail, Burns Flat

Oregon

BRYCE POINTER
1226 Juniper Ave., Reedsport 97467

Pennsylvania

G. WALDO MILLER
28 Rosemont Ave., Lewistown

ANTHONY P. MARK
345 Winton St., Philadelphia 19148

JOSEPH T. SUCHAR
1220 County Line Rd., Rosemont

T. R. S. CAMPBELL
602 S. Warren Ave., Malvern

Rhode Island
BRIAN WILDER
650 Tower Hill Rd., North Kingstown

Texas

JAMES W. KIRK
Box 58, A-Bar Hotel, Austin

JOHN W. BERRY
P.O. Box 240, Carswell AFB

Virginia

ERNEST DAVIS
3909 Rumford Ave., Virginia Beach

Wisconsin

RONALD A. WRIGHT
36 Reid Terr., Fond Du Lac

BRUCE T. KLEM
2463 S. 80th St., West Allis 19

PHILIP NEUSCHELER
1104 W. Johnson St., Madison

ROBERT NOONAN
2169 A S. 26th St., Milwaukee

Foreign

EDWARD F. LA CROIX
8 Hikawa-cho, Nakano-ku, Tokyo,

Japan

JOHN G. BRYANT
20 Boulevard Victor, Paris 15,

France

Due to the early publication closing date, many of you who have already subscribed do not appear in this issue's Directory. Never fear - your name, along with many others, will appear in the Directory for the following issue.